

# Husqvarna<sup>®</sup>

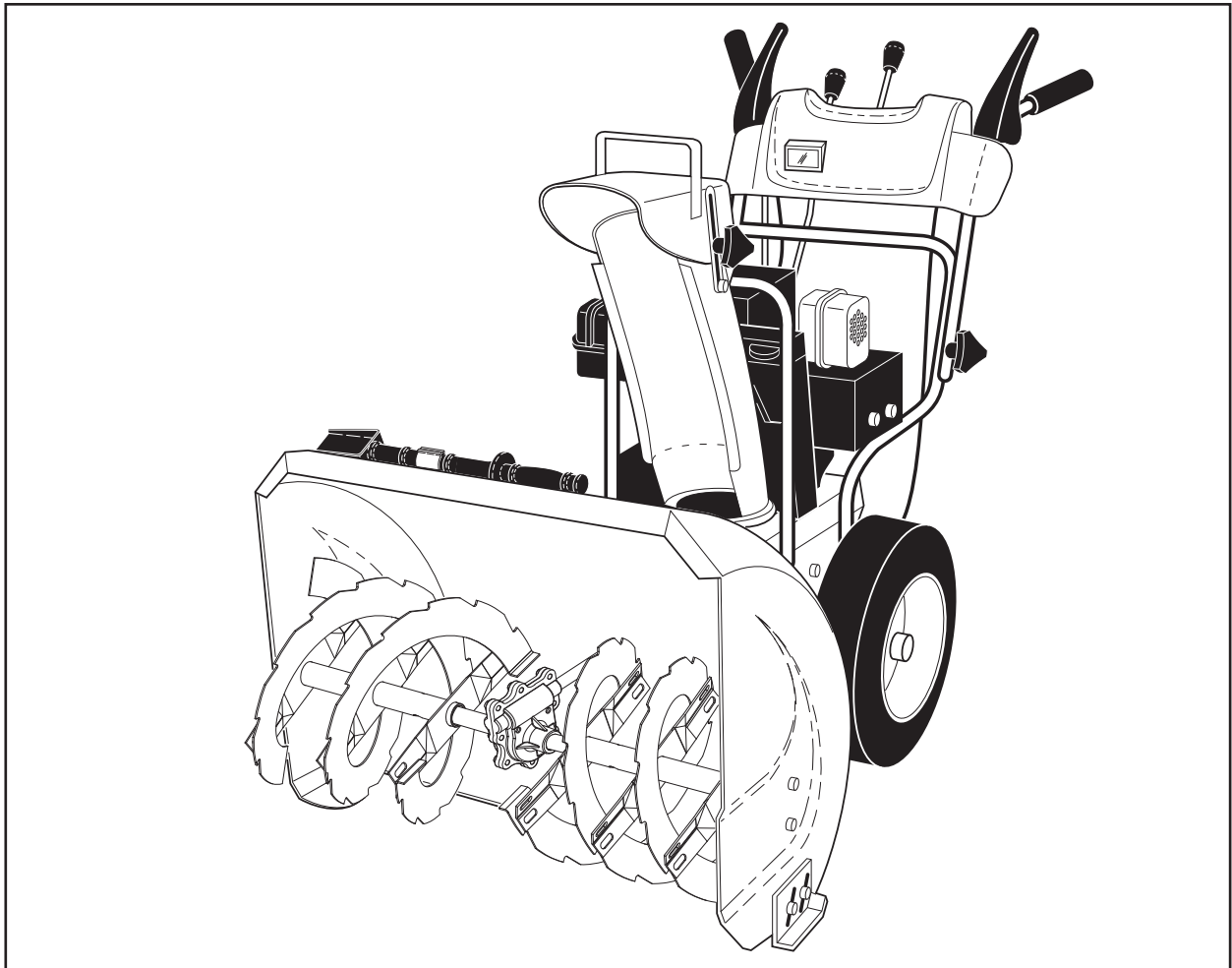

# 924SB

---

**Illustrated Parts List / 96193002600**

REPAIR PARTS

AUGER HOUSING / IMPELLER ASSEMBLY

SNOW THROWER - MODEL NO. 924SB (96193002600), PRODUCT NO. 961 93 00-26

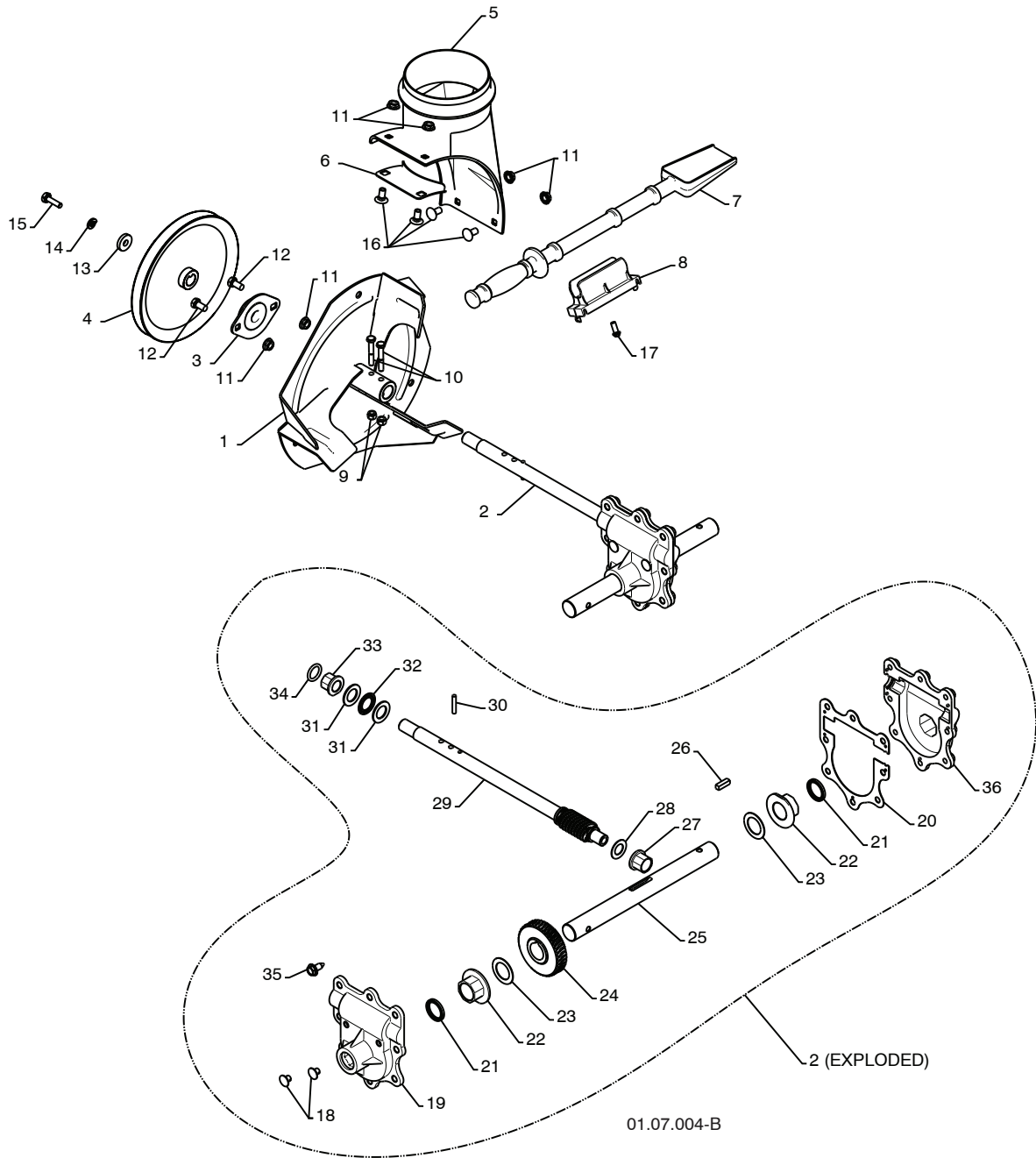

**REPAIR PARTS****AUGER HOUSING / IMPELLER ASSEMBLY****SNOW THROWER - MODEL NO. 924SB (96193002600), PRODUCT NO. 961 93 00-26**

<b>KEY NO.</b>	<b>PART NO.</b>	<b>DESCRIPTION</b>
1	532 18 41-05	IMPELLER
2	532 19 67-10	GEARBOX ASSEMBLY
3	532 18 89-09	BEARING
4	532 19 10-79	IMPELLER PULLEY
5	532 17 53-22	DISCHARGE BASE
6	532 18 40-95	CORNER BRACKET
7	532 19 21-99	CLEAN OUT TOOL
8	532 40 54-00	TOOL CLIP
9	873 80 04-00	NUT 1/4-20
10	874 78 04-26	SCREW 1/4-20 X .625
11	532 15 53-77	NUT 5/16-18
12	532 16 31-83	SCREW 5/16-18 X .625
13	819 11 15-07	WASHER
14	810 04 05-00	LOCKWASHER 5/16
15	874 94 05-16	SCREW 5/16-18 X 1.00
16	532 18 03-55	CARRIAGE BOLT
17	532 19 41-89	SCREW 13-16 X .625
18	532 40 77-60	PLUG
19	532 40 77-61	GEARBOX COVER RH
20	532 40 77-66	GASKET
21	532 40 77-70	SEAL
22	532 40 77-62	BEARING
23	532 17 46-97	THRUST WASHER 1.00
24	532 40 77-63	WORM GEAR
25	532 40 77-64	AUGER SHAFT
26	532 18 92-82	SQUARE KEY
27	532 40 77-58	BEARING
28	532 17 46-83	THRUST WASHER
29	532 40 77-57	IMPELLER SHAFT
30	532 18 42-05	ROLL PIN
31	532 17 46-81	THRUST WASHER
32	532 17 46-84	THRUST BEARING
33	532 40 77-69	BEARING
34	532 40 77-68	O-RING
35	532 40 77-67	SCREW 5/16-18 X .750
36	532 40 77-65	GEARBOX COVER LH

**NOTE:** All component dimensions given in U.S. inches. 1 inch = 25.4 mm

**IMPORTANT:** Use only Original Equipment Manufacturer (O.E.M.) replacement parts. Failure to do so could be hazardous, damage your snow thrower and void your warranty.

# REPAIR PARTS

# AUGER HOUSING / IMPELLER ASSEMBLY

SNOW THROWER - MODEL NO. 924SB (96193002600), PRODUCT NO. 961 93 00-26

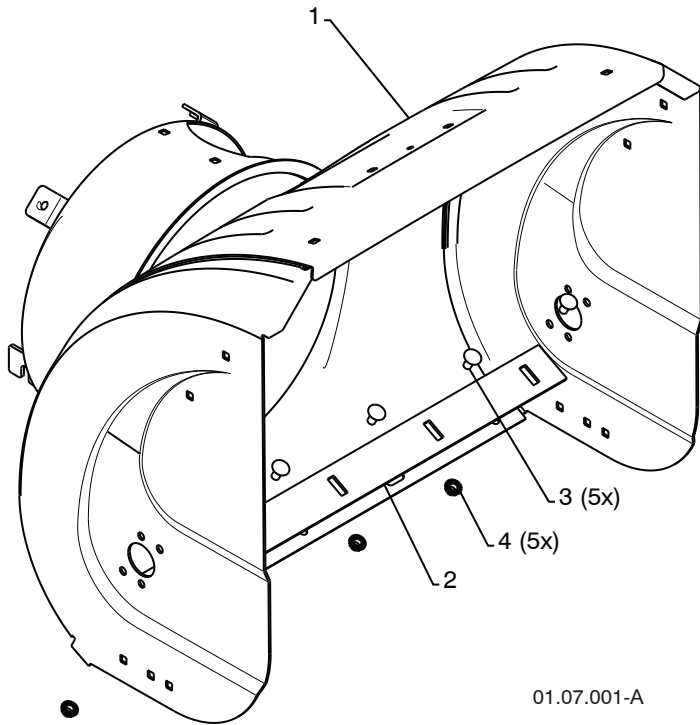

01.07.001-A

KEY NO.	PART NO.	DESCRIPTION
1	532 40 78-80	AUGER HOUSING
2	532 40 78-25	SCRAPPER BAR
3	872 27 05-05	CARRIAGE BOLT 5/16-18 X .625
4	532 15 53-77	NUT 5/16-18

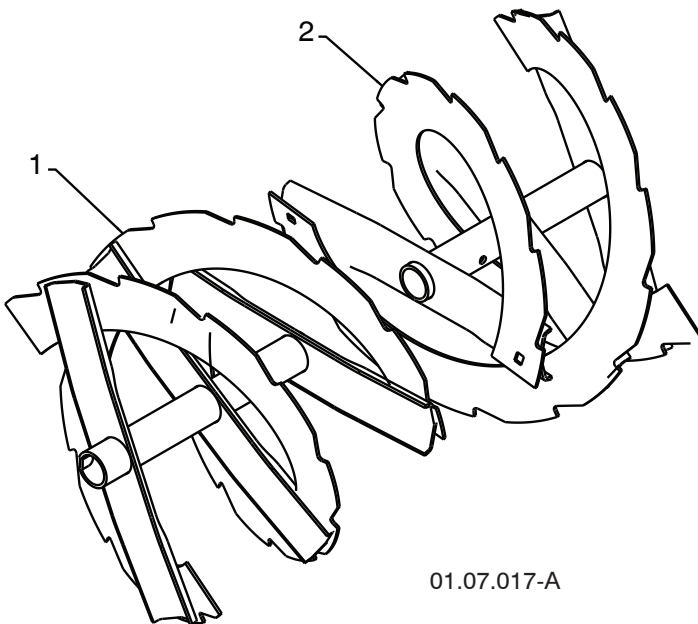

01.07.017-A

KEY NO.	PART NO.	DESCRIPTION
1	532 42 10-72	AUGER ASSEMBLY LH 24
2	532 42 10-73	AUGER ASSEMBLY RH 24

**NOTE:** All component dimensions given in U.S. inches. 1 inch = 25.4 mm  
**IMPORTANT:** Use only Original Equipment Manufacturer (O.E.M.) replacement parts. Failure to do so could be hazardous, damage your snow thrower and void your warranty.

# REPAIR PARTS

# AUGER HOUSING / IMPELLER ASSEMBLY

SNOW THROWER - MODEL NO. **924SB** (96193002600), PRODUCT NO. 961 93 00-26

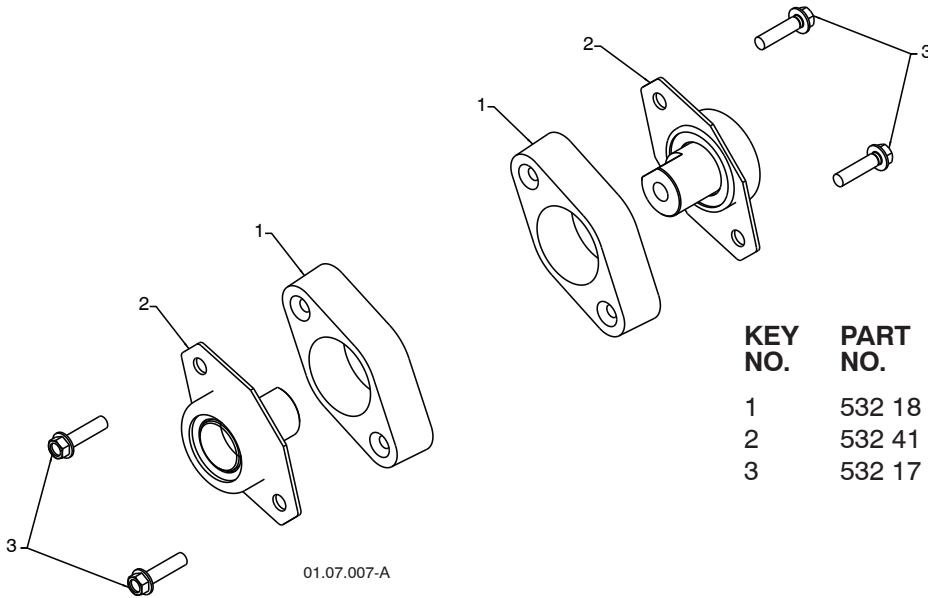

01.07.007-A

KEY NO.	PART NO.	DESCRIPTION
1	532 18 81-70	PLASTIC RETAINER
2	532 41 18-33	AUGER BALL BEARING
3	532 17 95-82	SCREW 5/16-18 X 1.00

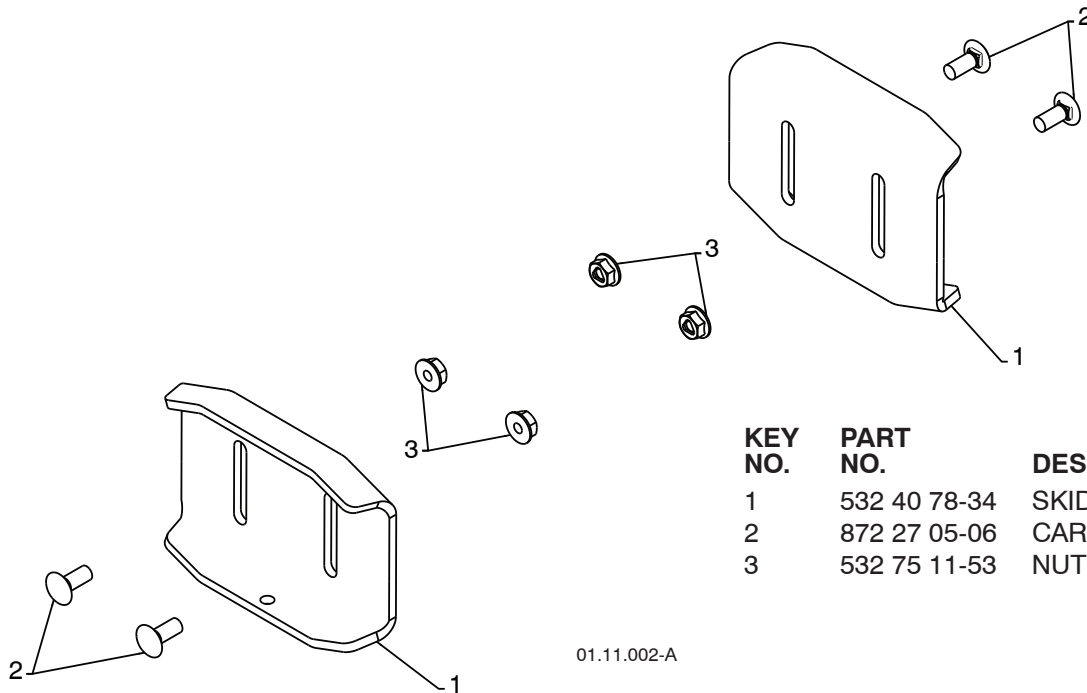

01.11.002-A

KEY NO.	PART NO.	DESCRIPTION
1	532 40 78-34	SKID PLATE
2	872 27 05-06	CARRIAGE BOLT 5/16-18 X .750
3	532 75 11-53	NUT 5/16-18

**NOTE:** All component dimensions given in U.S. inches. 1 inch = 25.4 mm  
**IMPORTANT:** Use only Original Equipment Manufacturer (O.E.M.) replacement parts.  
 Failure to do so could be hazardous, damage your snow thrower and void your warranty.

# REPAIR PARTS

# CONTROL PANEL / DISCHARGE CHUTE

SNOW THROWER - MODEL NO. **924SB** (96193002600), PRODUCT NO. 961 93 00-26

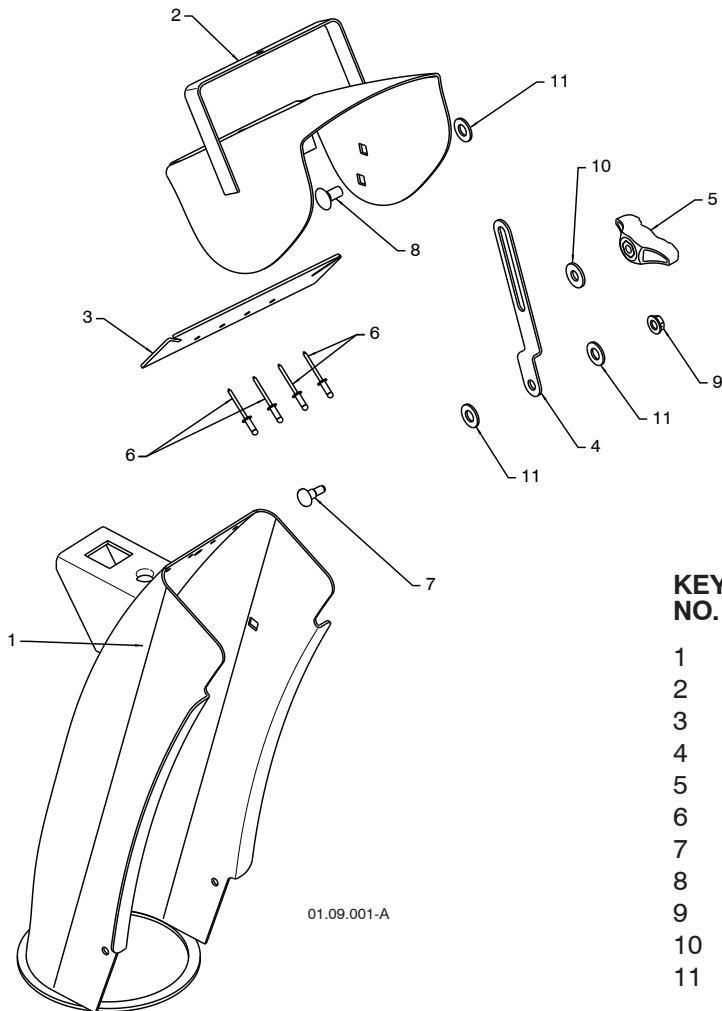

KEY NO.	PART NO.	DESCRIPTION
1	532 40 76-50	CHUTE WELDMENT
2	532 18 41-13	DEFLECTOR WELDMENT
3	532 42 03-25	DEFLECTOR SEAL
4	532 18 41-14	STRAP
5	532 19 19-38	KNOB BLACK
6	532 12 84-15	POP RIVET
7	532 18 56-00	SHOULDER BOLT 1/4-20 X .704
8	872 27 05-05	CARRIAGE BOLT 5/16-18 X .625
9	532 19 17-30	NUT 1/4-20
10	532 15 54-15	WASHER
11	532 17 92-46	PLASTIC WASHER

**NOTE:** All component dimensions given in U.S. inches. 1 inch = 25.4 mm  
**IMPORTANT:** Use only Original Equipment Manufacturer (O.E.M.) replacement parts.  
 Failure to do so could be hazardous, damage your snow thrower and void your warranty.

# REPAIR PARTS

# CONTROL PANEL / DISCHARGE CHUTE

SNOW THROWER - MODEL NO. 924SB (96193002600), PRODUCT NO. 961 93 00-26

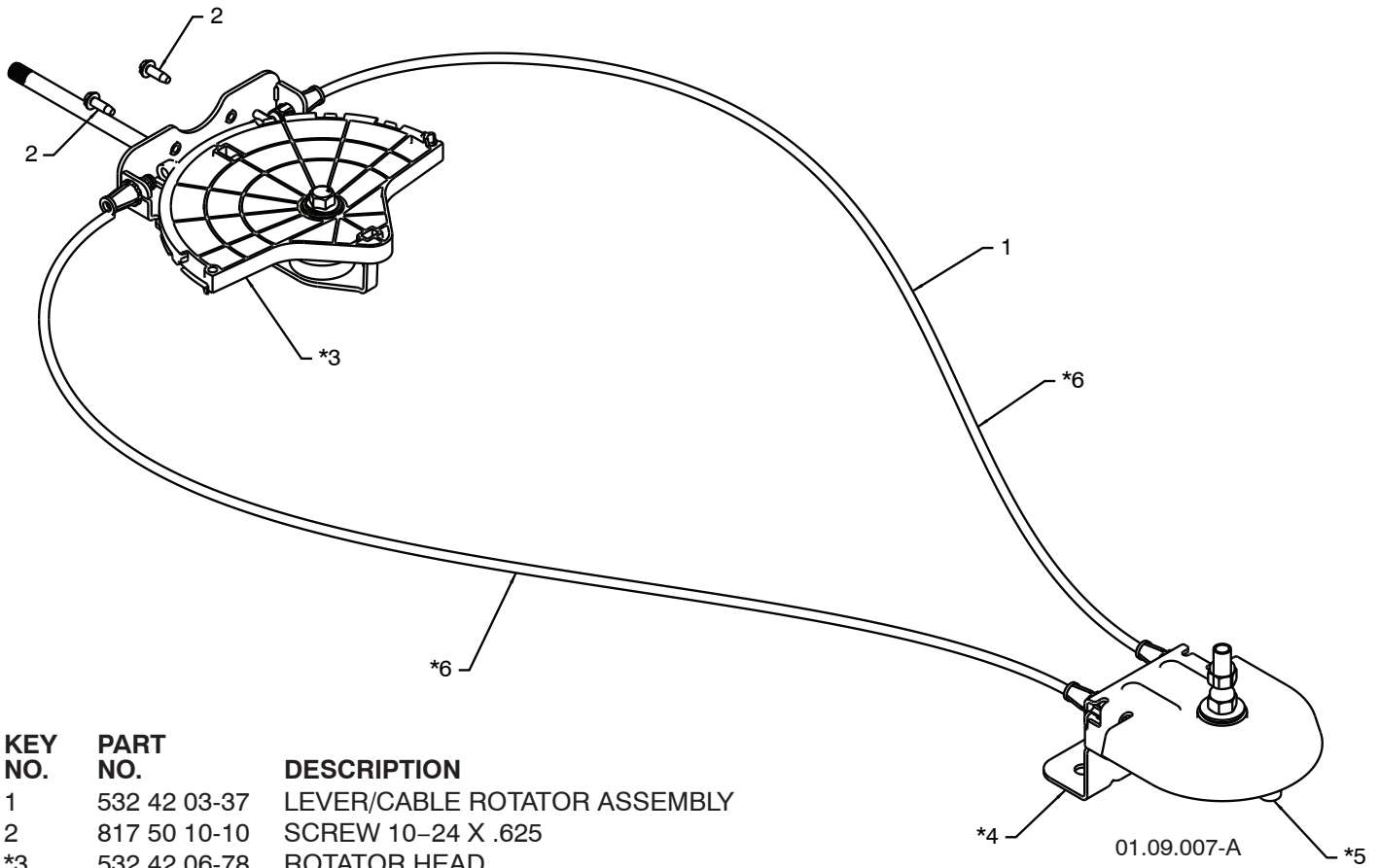

KEY NO.	PART NO.	DESCRIPTION
1	532 42 03-37	LEVER/CABLE ROTATOR ASSEMBLY
2	817 50 10-10	SCREW 10-24 X .625
*3	532 42 06-78	ROTATOR HEAD
*4	532 42 06-77	ROTATOR PIVOT BRACKET
*5	532 42 06-75	PULLEY PIVOT
*6	532 42 06-74	CABLE ASSEMBLY

### NOTES:

1. ITEMS INDICATED WITH AN \* ARE LISTED AS REFERENCE FOR SERVICE PARTS ONLY.

**NOTE:** All component dimensions given in U.S. inches. 1 inch = 25.4 mm  
**IMPORTANT:** Use only Original Equipment Manufacturer (O.E.M.) replacement parts.  
Failure to do so could be hazardous, damage your snow thrower and void your warranty.

# REPAIR PARTS

# HANDLES

SNOW THROWER - MODEL NO. 924SB (96193002600), PRODUCT NO. 961 93 00-26

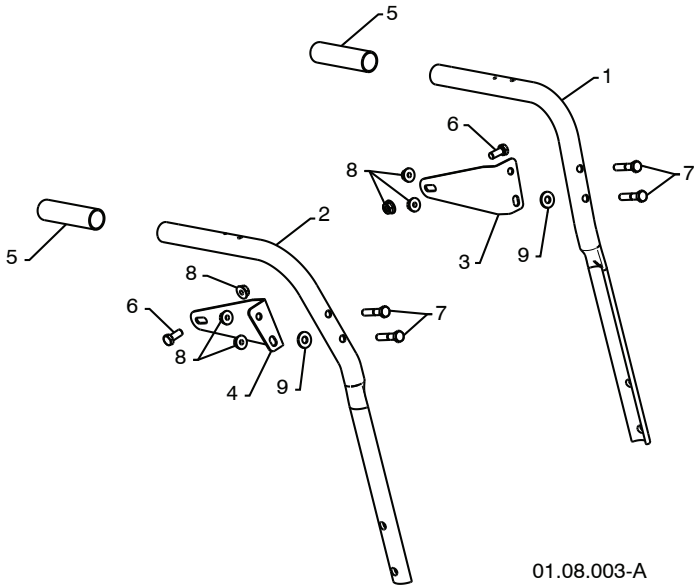

01.08.003-A

KEY NO.	PART NO.	DESCRIPTION
1	532 42 10-69	PLOW HANDLE LH
2	532 42 10-70	PLOW HANDLE RH
3	532 19 69-44	PANEL BRACKET LH
4	532 19 69-43	PANEL BRACKET RH
5	532 19 95-13	HANDLE GRIP
6	874 78 05-12	SCREW 5/16-18 X .750
7	874 78 05-24	SCREW 5/16-18 X 1.50
8	532 75 11-53	NUT 5/16-18
9	532 15 54-15	WASHER

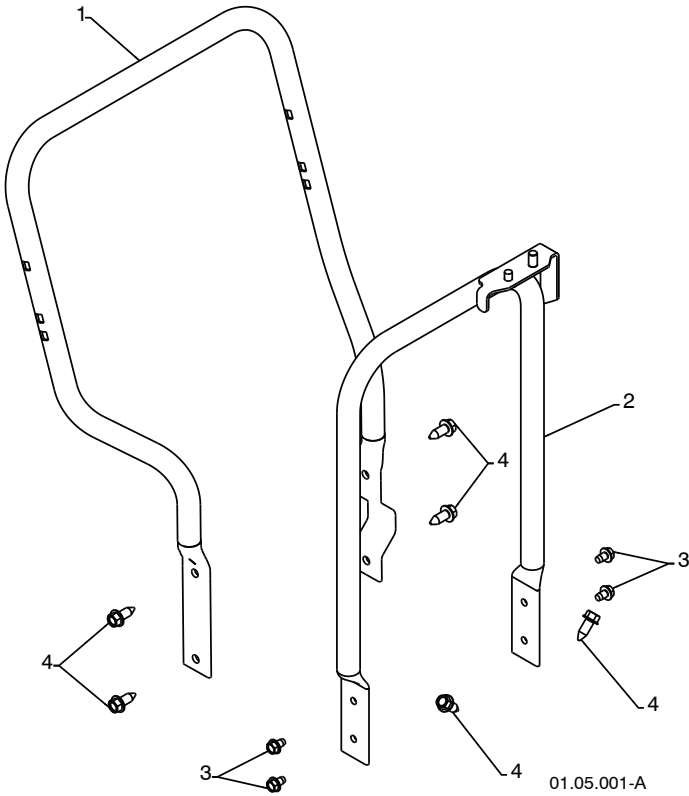

01.05.001-A

KEY NO.	PART NO.	DESCRIPTION
1	532 42 10-59	LOWER TUBE
2	532 40 76-43	PIVOT SUPPORT
3	817 49 05-08	BOLT 5/16-18 X .500
4	817 00 06-16	SCREW 3/8-16 X 1.00

**NOTE:** All component dimensions given in U.S. inches. 1 inch = 25.4 mm  
**IMPORTANT:** Use only Original Equipment Manufacturer (O.E.M.) replacement parts.  
 Failure to do so could be hazardous, damage your snow thrower and void your warranty.



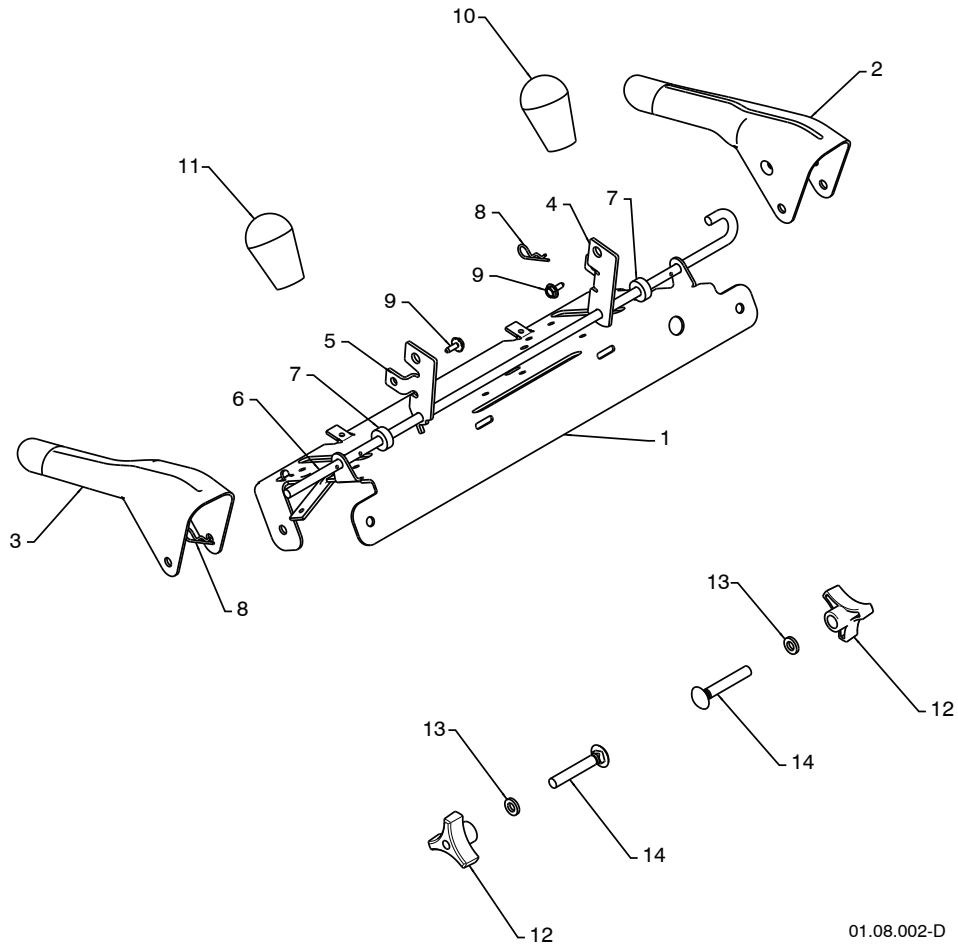

01.08.002-D

KEY NO.	PART NO.	DESCRIPTION
1	532 41 55-39	CONTROL PANEL
2	532 41 55-41	CONTROL LEVER LH
3	532 41 55-42	CONTROL LEVER RH
4	532 41 55-46	TRACTION ROD ARM
5	532 42 14-92	IMPELLER ROD ARM
6	532 41 26-77	INTERLOCK ROD
7	532 41 26-80	SPACER
8	532 16 96-75	RETAINER
9	817 06 04-08	SCREW 1/4-20 X .50
10	532 41 42-80	KNOB BLACK
11	532 41 42-81	KNOB RED
12	532 17 88-99	HANDLE KNOB
13	819 13 13-16	WASHER 3/8
14	872 12 06-18	CARRIAGE BOLT 3/8-16 X 2.25

**NOTE:** All component dimensions given in U.S. inches. 1 inch = 25.4 mm  
**IMPORTANT:** Use only Original Equipment Manufacturer (O.E.M.) replacement parts.  
 Failure to do so could be hazardous, damage your snow thrower and void your warranty.

# REPAIR PARTS

# HANDLES

SNOW THROWER - MODEL NO. 924SB (96193002600), PRODUCT NO. 961 93 00-26

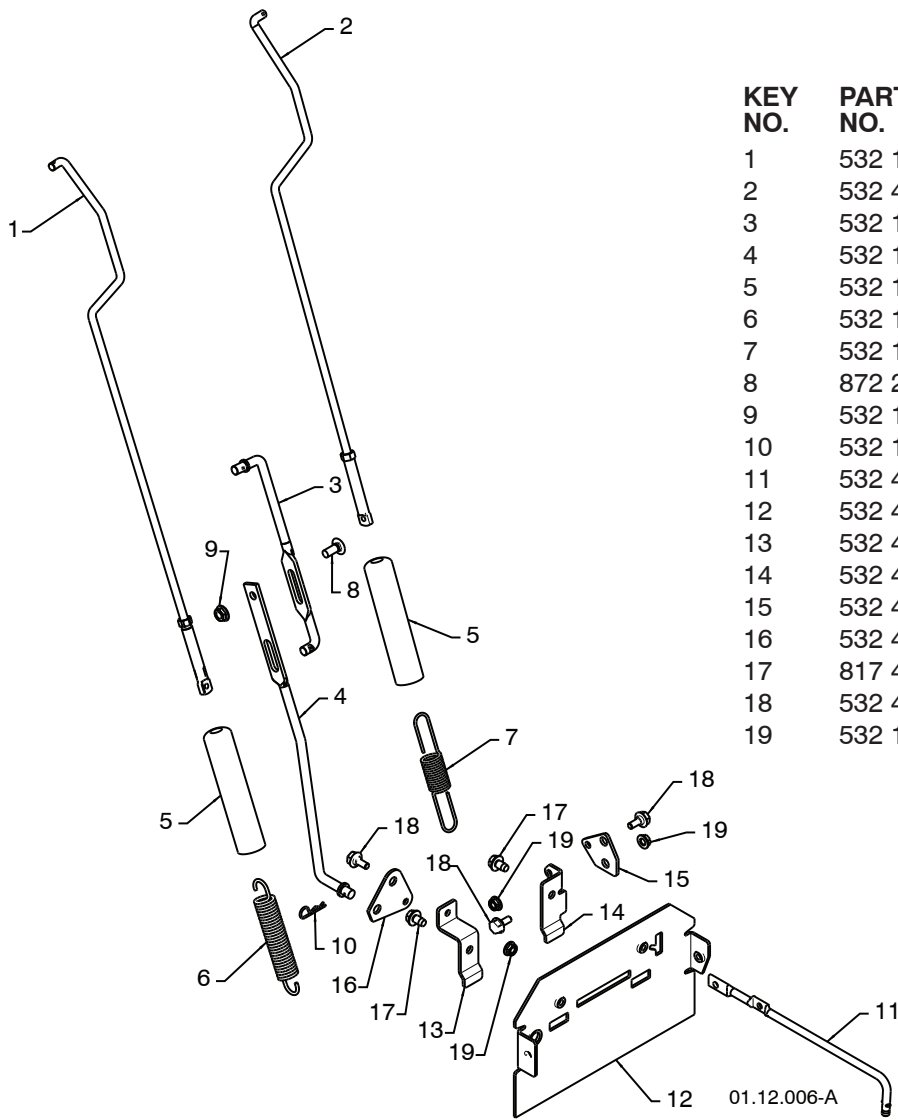

KEY NO.	PART NO.	DESCRIPTION
1	532 18 04-80	IMPELLER ROD ASSEMBLY
2	532 40 57-40	TRACTION ROD ASSEMBLY
3	532 18 04-45	SHIFTER ROD TOP
4	532 18 77-16	SHIFTER ROD BOTTOM
5	532 18 04-47	SPRING SLEEVE
6	532 17 86-69	IMPELLER SPRING
7	532 18 09-26	TRACTION SPRING
8	872 27 05-06	CARRIAGE BOLT 5/16-18 X .750
9	532 15 53-77	NUT 5/16-18
10	532 16 96-75	RETAINER
11	532 40 33-00	CLUTCH ROD
12	532 41 69-21	REAR PLATE
13	532 41 54-33	SHIFTER PLATE BRACKET
14	532 41 68-64	CLUTCH PLATE BRACKET
15	532 41 54-35	CLUTCH PLATE
16	532 41-54-50	SHIFTER PLATE
17	817 49 05-08	BOLT 5/16-18 X .500
18	532 40 28-81	SHOULDER BOLT 1/4-20 X .500
19	532 19 17-30	NUT 1/4-20

**NOTE:** All component dimensions given in U.S. inches. 1 inch = 25.4 mm  
**IMPORTANT:** Use only Original Equipment Manufacturer (O.E.M.) replacement parts.  
 Failure to do so could be hazardous, damage your snow thrower and void your warranty.

# REPAIR PARTS

# HANDLES

SNOW THROWER - MODEL NO. **924SB** (96193002600), PRODUCT NO. 961 93 00-26

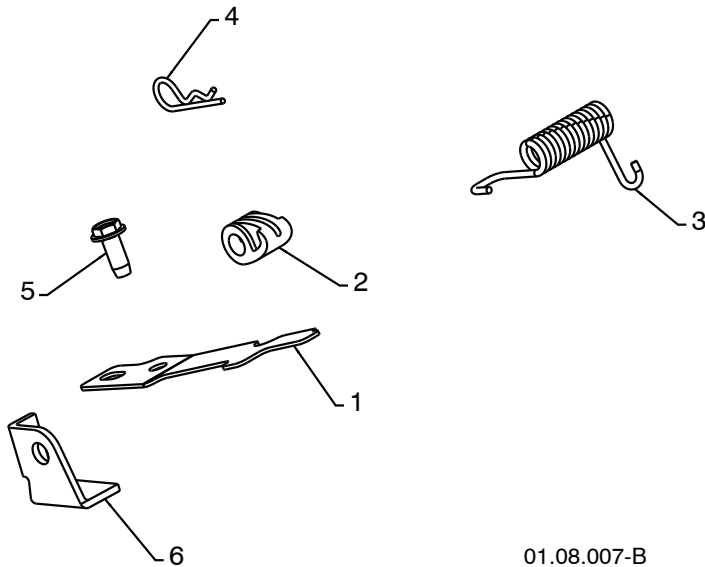

KEY NO.	PART NO.	DESCRIPTION
1	532 41 62-88	INTERLOCK SPRING
2	532 41 45-72	INTERLOCK CAM
3	532 17 88-31	TORSION SPRING
4	532 16 96-75	RETAINER
5	817 06 04-10	SCREW 1/4-20 X .625
6	532 42 12-52	INTERLOCK STOP

01.08.007-B

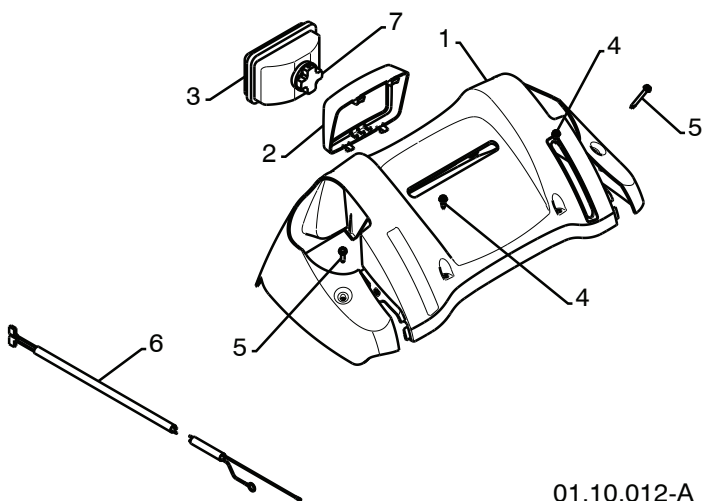

KEY NO.	PART NO.	DESCRIPTION
1	532 42 13-81	CONSOLE PANEL GRAY
2	532 42 14-48	HEADLIGHT BEZEL GRAY
3	532 18 09-27	FLOOD HEADLIGHT
4	532 18 44-71	SHOULDER SCREW 10-24 X .625
5	532 17 52-62	SCREW 10-24 X 1.25
6	532 17 87-70	WIRE HARNESS
7	532 18 37-84	BULB

01.10.012-A

**NOTE:** All component dimensions given in U.S. inches. 1 inch = 25.4 mm  
**IMPORTANT:** Use only Original Equipment Manufacturer (O.E.M.) replacement parts.  
 Failure to do so could be hazardous, damage your snow thrower and void your warranty.

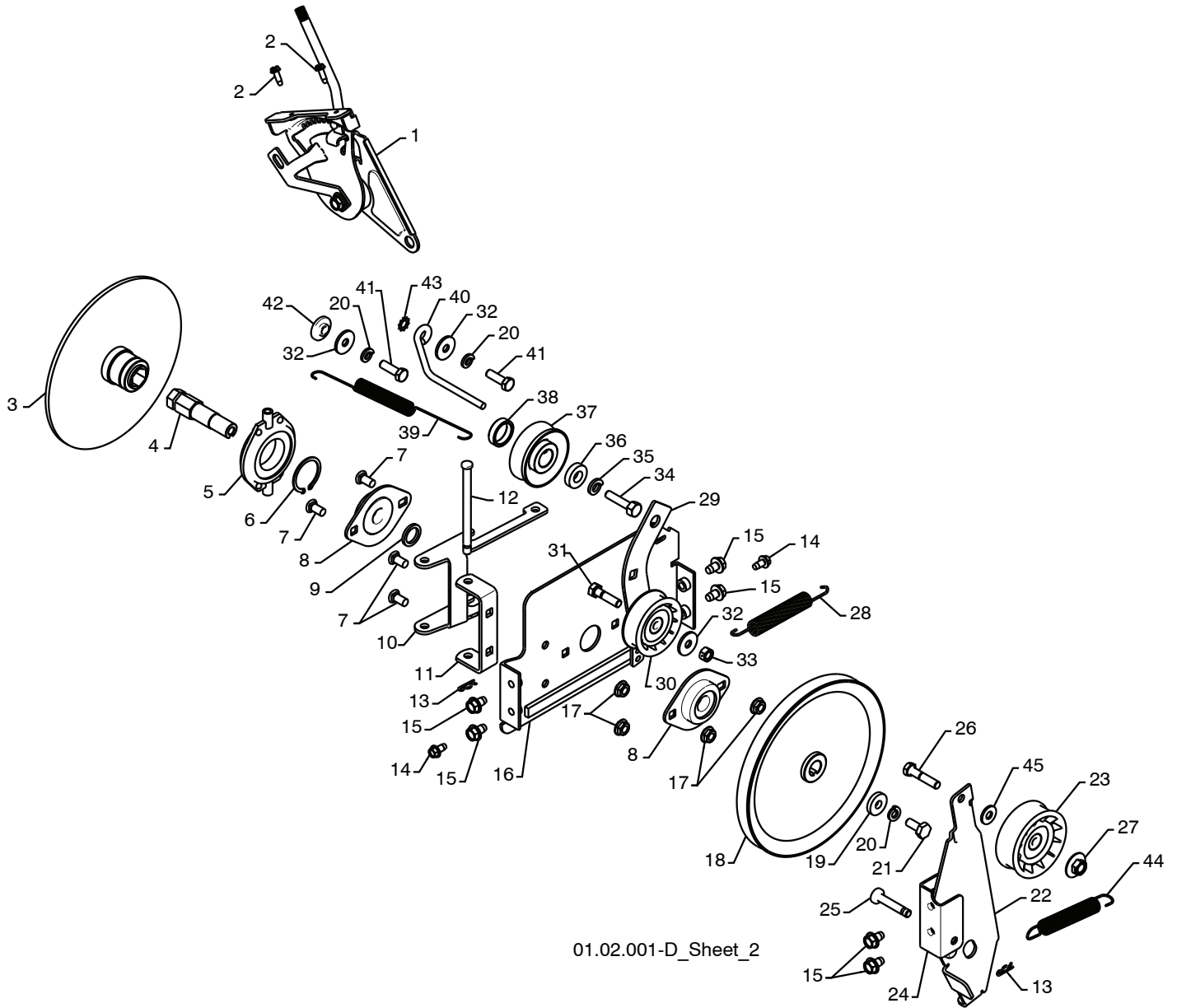

01.02.001-D\_Sheet\_2

SNOW THROWER - MODEL NO. **924SB** (96193002600), PRODUCT NO. 961 93 00-26

KEY NO.	PART NO.	DESCRIPTION
1	532 19 84-74	SPEED SELECTOR HEAD ASSEMBLY
2	817 50 10-10	SCREW 10-24 X .625
3	532 19 77-63	DRIVE PLATE WELDMENT
4	532 19 77-64	HEX SHAFT
5	532 17 53-44	TRUNNION BEARING ASSEMBLY
6	812 00 00-12	RETAINER
7	872 27 05-05	CARRIAGE BOLT 5/16-18 X .625
8	532 18 89-09	FLANGE BEARING
9	532 18 25-04	SPACER
10	532 18 40-77	LEVER SHIFTER PLATE
11	532 18 40-76	SHIFTER SUPPORT BRACKET
12	532 17 86-95	PIN
13	532 08 51-79	RETAINER
14	817 49 04-08	SCREW 1/4-20 X .500
15	817 49 05-08	BOLT 5/16-18 X .500
16	532 18 40-75	DRIVE MOUNT PLATE
17	532 15 53-77	NUT 5/16-18
18	532 19 10-80	TRACTION PULLEY
19	819 11 15-07	WASHER
20	810 04 05-00	LOCKWASHER 5/16
21	874 95 05-12	SCREW 5/16-18 X .750
22	532 41 99-25	IDLER BRAKE ARM
23	532 18 05-23	IDLER PULLEY
24	532 18 40-74	IDLER PIVOT BRACKET
25	532 17 53-30	PIN
26	874 78 05-24	SCREW 5/16-18 X 1.50
27	532 16 67-85	NUT 5/16-18
28	532 18 10-44	TRACTION SPRING
29	532 17 93-54	IDLER TRACTION ARM
30	532 18 05-22	IDLER PULLEY
31	874 78 05-20	SCREW 5/16-18 X 1.25
32	532 05 92-89	WASHER
33	873 93 05-00	NUT 5/16-18
34	532 85 10-84	SCREW 3/8-24 X 1.38
35	532 85 02-63	LOCKWASHER 3/8
36	532 40 00-26	WASHER
37	532 18 04-78	ENGINE TRACTION PULLEY
38	532 40 94-75	SPACER
39	532 17 90-95	RETURN SPRING
40	532 15 54-52	BELT GUIDE
41	874 61 05-16	SCREW 5/16-18 X 1.00
42	532 17 53-31	BUSHING
43	811 05 05-00	LOCKWASHER 5/16
44	532 17 88-28	BRAKE SPRING
45	532 15 54-15	WASHER

**NOTE:** All component dimensions given in U.S. inches. 1 inch = 25.4 mm

**IMPORTANT:** Use only Original Equipment Manufacturer (O.E.M.) replacement parts. Failure to do so could be hazardous, damage your snow thrower and void your warranty.



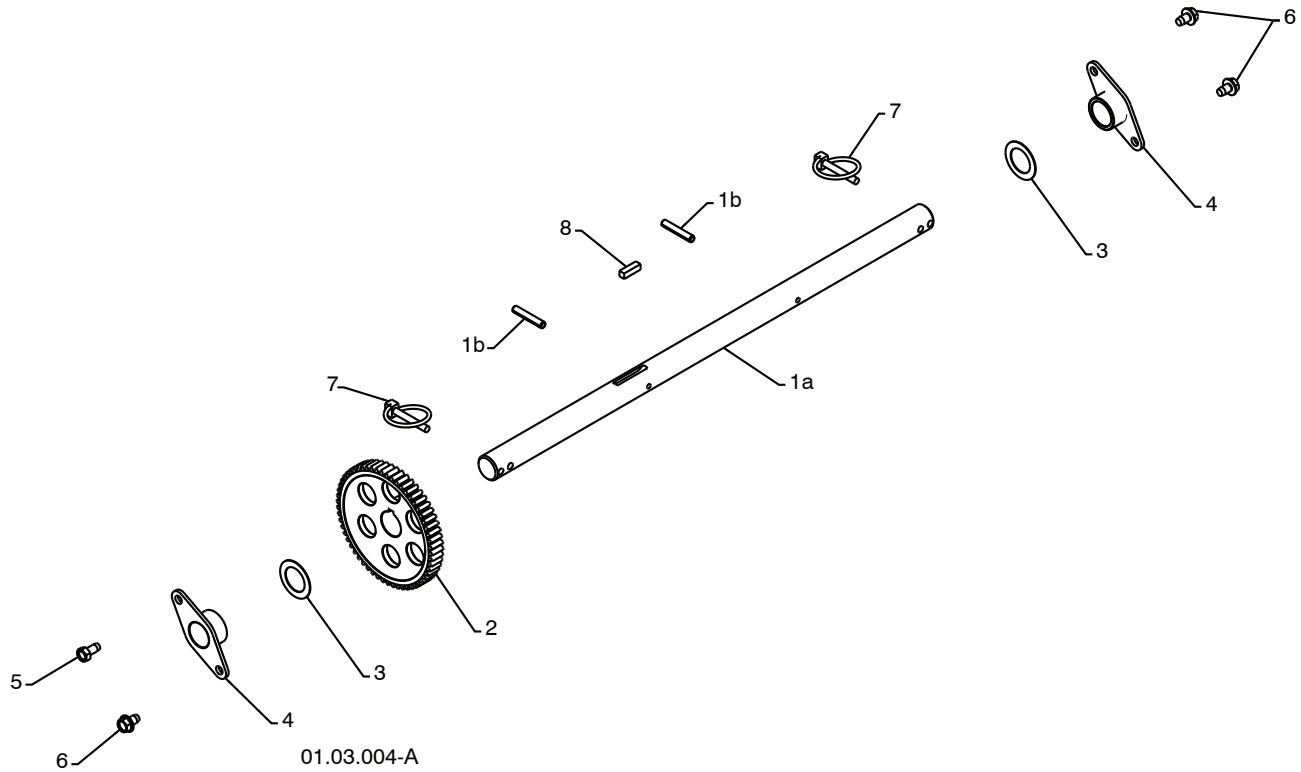

KEY NO.	PART NO.	DESCRIPTION
1	532 18 82-26	(assy of 1a,1b) AXLE ASSEMBLY
1a	532 17 93-52	AXLE SHAFT
1b	532 18 42-06	ROLL PIN 3/16
2	532 18 00-81	GEAR
3	532 17 46-97	THRUST WASHER
4	532 17 98-30	BEARING
5	532 14 63-15	SCREW 5/16-18 X .625
6	817 49 05-08	BOLT 5/16-18 X .500
7	532 15 54-43	CLIK PIN
8	532 18 92-82	SQUARE KEY

**NOTE:** All component dimensions given in U.S. inches. 1 inch = 25.4 mm  
**IMPORTANT:** Use only Original Equipment Manufacturer (O.E.M.) replacement parts. Failure to do so could be hazardous, damage your snow thrower and void your warranty.

# REPAIR PARTS

# CHASSIS / ENGINE / PULLEYS

SNOW THROWER - MODEL NO. **924SB** (96193002600), PRODUCT NO. 961 93 00-26

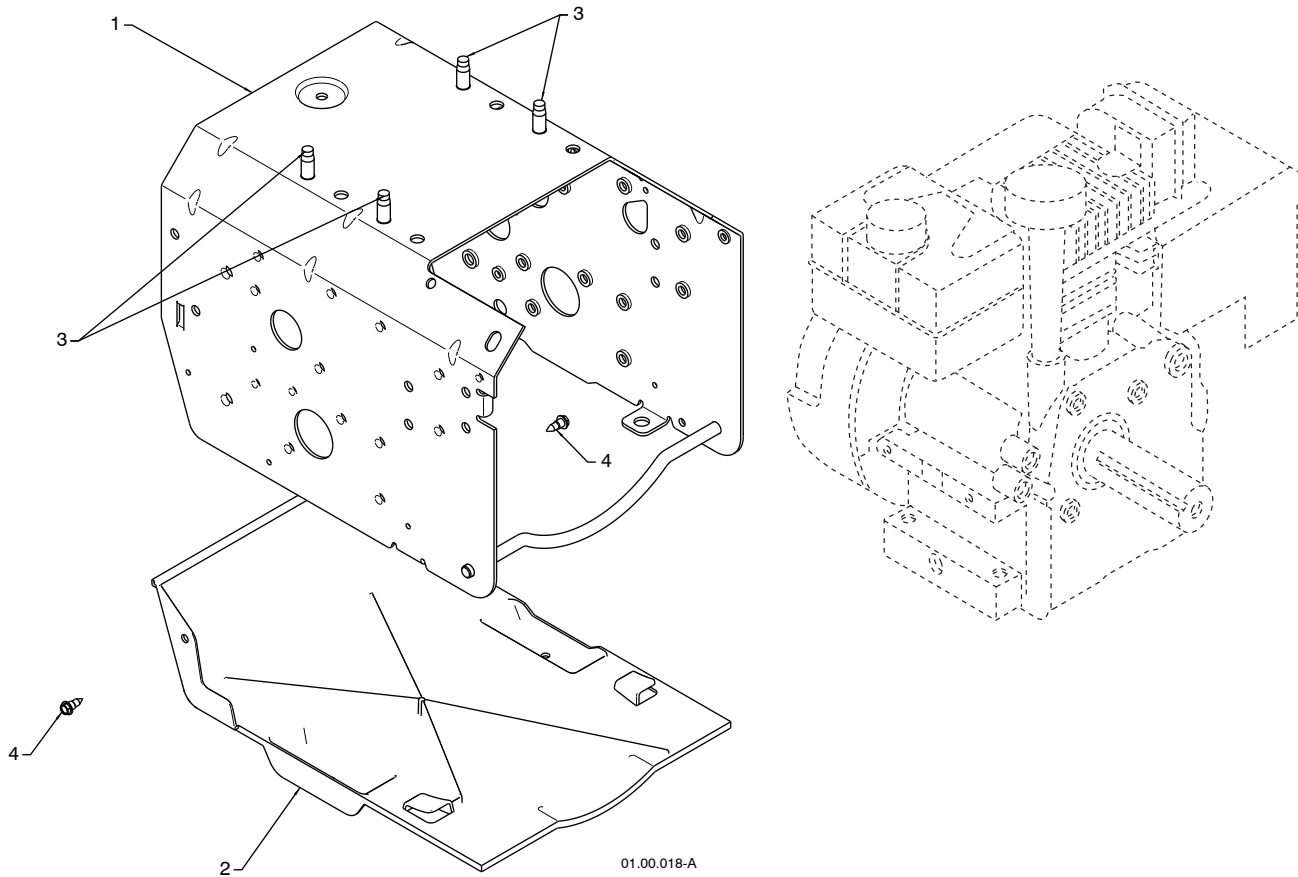

KEY NO.	PART NO.	DESCRIPTION
--	-----	TECUMSEH ENGINE MODEL LH318SA-156597H
1	532 41 61-55	FRAME
2	532 41 08-77	BOTTOM PAN
3	532 15 04-06	BOLT 3/8-16
4	532 18 44-71	SCREW 10-24 X .625

**NOTE:** All component dimensions given in U.S. inches. 1 inch = 25.4 mm  
**IMPORTANT:** Use only Original Equipment Manufacturer (O.E.M.) replacement parts.  
 Failure to do so could be hazardous, damage your snow thrower and void your warranty.



# REPAIR PARTS

# CHASSIS / ENGINE / PULLEYS

SNOW THROWER - MODEL NO. **924SB** (96193002600), PRODUCT NO. 961 93 00-26

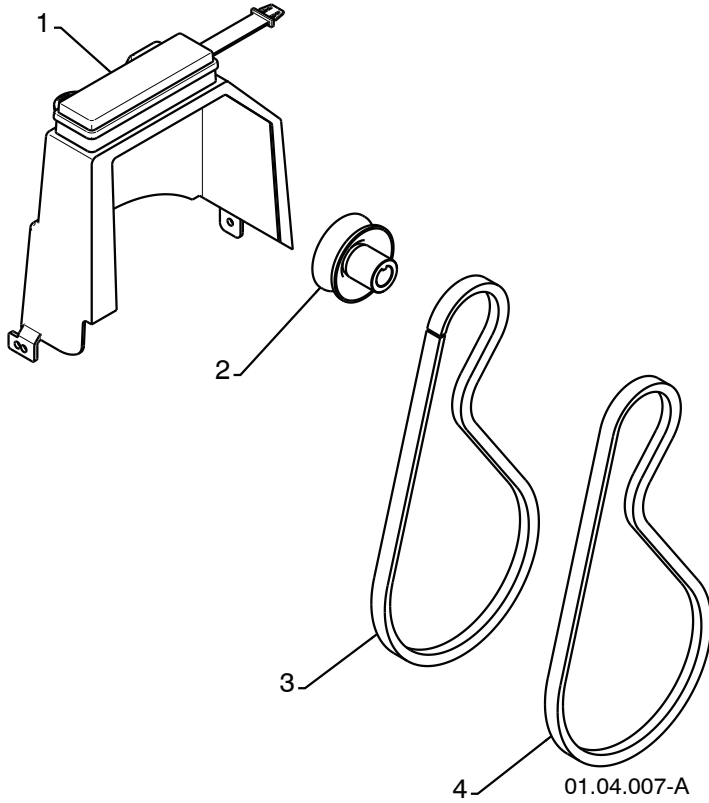

KEY NO.	PART NO.	DESCRIPTION
1	532 19 22-13	COVER ASSEMBLY
2	532 17 91-57	PULLEY
3	532 41 97-44	TRACTION BELT
4	532 40 80-10	IMPELLER BELT

**NOTE:** All component dimensions given in U.S. inches. 1 inch = 25.4 mm  
**IMPORTANT:** Use only Original Equipment Manufacturer (O.E.M.) replacement parts.  
Failure to do so could be hazardous, damage your snow thrower and void your warranty.

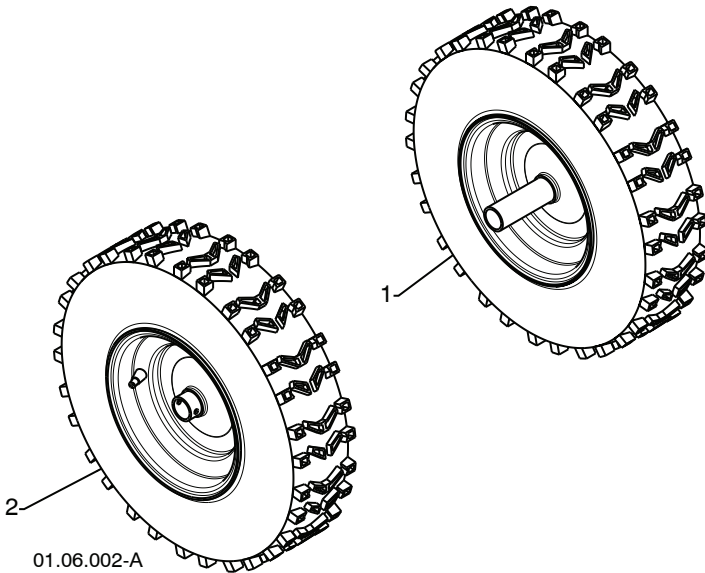

KEY NO.	PART NO.	DESCRIPTION
1	532 42 17-30	WHEEL ASSEMBLY LH
2	532 42 17-31	WHEEL ASSEMBLY RH

**NOTE:** All component dimensions given in U.S. inches. 1 inch = 25.4 mm  
**IMPORTANT:** Use only Original Equipment Manufacturer (O.E.M.) replacement parts.  
 Failure to do so could be hazardous, damage your snow thrower and void your warranty.

**REPAIR PARTS**

**BAG OF PARTS**

**SNOW THROWER - MODEL NO. 924SB (96193002600), PRODUCT NO. 961 93 00-26**

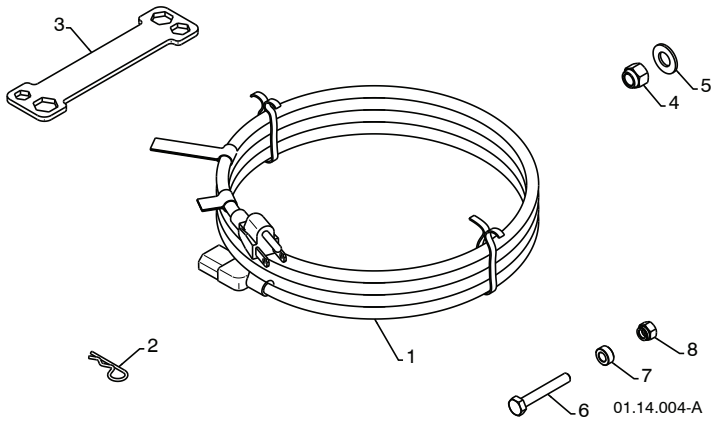

KEY NO.	PART NO.	DESCRIPTION
1	532 19 85-63	POWER CORD
2	532 16 96-75	RETAINER PIN
3	532 18 06-84	WRENCH
4	873 80 06-00	LOCKNUT 3/8-16
5	819 13 13-16	WASHER 3/8
6	532 19 86-36	SHEAR BOLT 1/4-20 X 1-3/4
7	532 19 86-38	SPACER
8	873 80 04-00	LOCKNUT 1/4-20

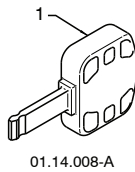

KEY NO.	PART NO.	DESCRIPTION
1	35062	SAFETY IGNITION KEY

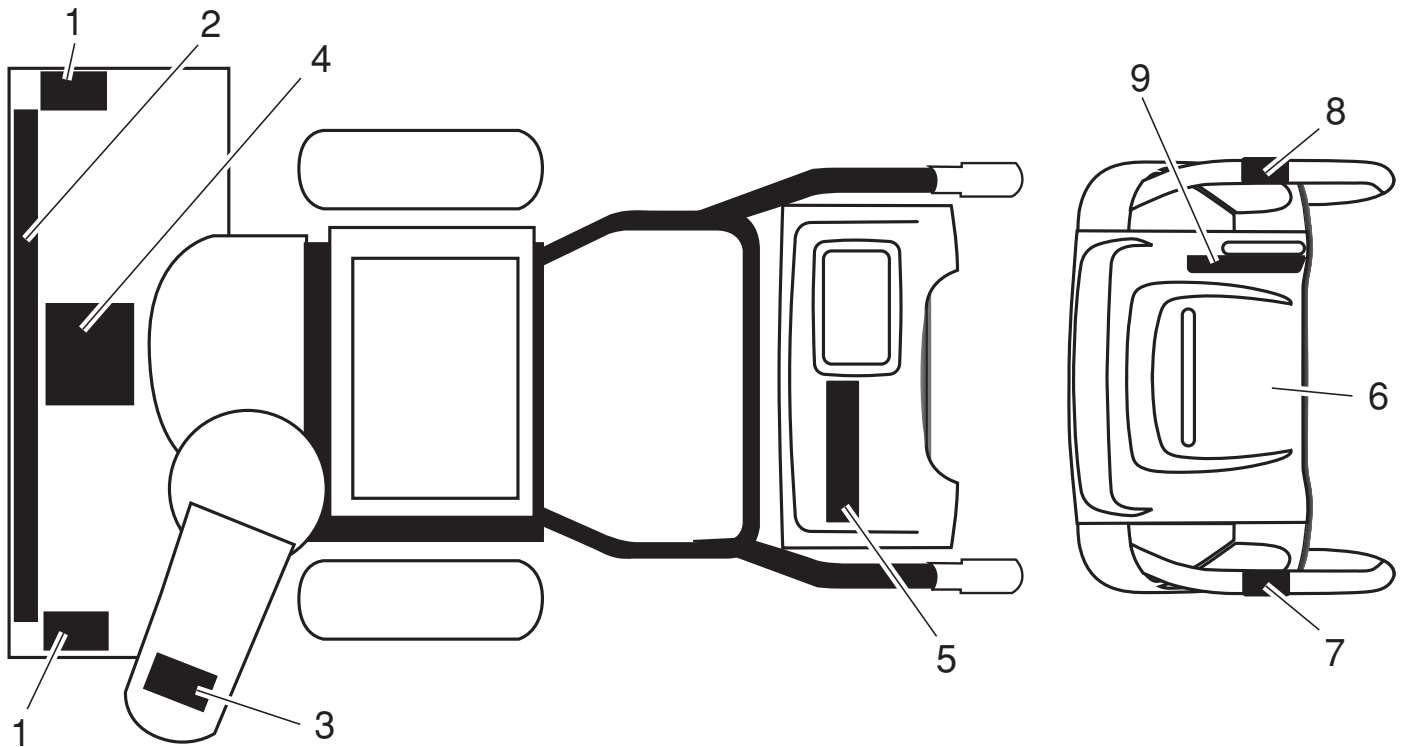

KEY PART NO.	PART NO.	DESCRIPTION
1	532 18 10-37	DECAL, DANGER
2	532 42 10-38	DECAL, HUSQVARNA
3	532 18 10-35	DECAL, DANGER, DEFLECTOR
4	532 18 10-42	DECAL, DANGER
5	532 42 10-37	DECAL, HUSQVARNA, 924SB
6	532 18 10-33	DECAL, INSTRUCTION
7	532 41 53-91	DECAL, TRACTION LEVER
8	532 41 53-90	DECAL, AUGER LEVER
9	532 41 54-75	DECAL, SPEED CONTROL
--	532 42 09-35	OWNER'S MANUAL, ENGLISH
--	532 42 09-36	OWNER'S MANUAL, FRENCH

**NOTE:** All component dimensions given in U.S. inches. 1 inch = 25.4 mm  
**IMPORTANT:** Use only Original Equipment Manufacturer (O.E.M.) replacement parts.  
 Failure to do so could be hazardous, damage your snow thrower and void your warranty.